

ELECTRIC ACTUATOR TYPE NA / NA-X

GENERAL CHARACTERISTICS

The NA electric actuator is dedicated to the actuation of industrial ¼ turn valve. The maximum torque value is 2500 Nm. With a compact design, an IP 67 cast aluminium enclosure and an epoxy protection, the NA electric actuator is especially adapted to the actuation of ball valves and butterfly valves in dusty outdoor or indoor areas. It is equipped with a declutchable manual override and a torque limiter (except on NA06 and NA09). Many options are available. The NA-X version can be used in explosive areas 1 and 2 and complies with the EN 15714-2 standard.

AVAILABLE MODELS

NA06: 60 Nm to NA250: 2500 Nm

Voltage: 230 V AC, 400 V AC, 24 V AC, 24 V DC

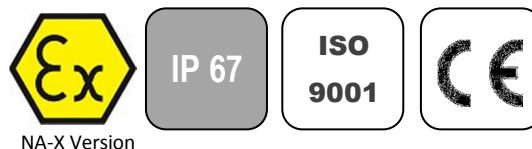

LIMITS OF USE

Version	NA	NA-X
Protection rating	IP 67	
Temperature range	-20 °C / +70 °C	-20 °C / +55 °C
Service	S2-70%	
Explosive areas	Forbidden	Zone 1 and 2



MECHANICAL CHARACTERISTICS

Gears	Treated steel pinions
Rotation angle	90° +/- 5°
Declutching	Lever
Manual override	Handwheel
Torque limiter	Except for NA06 and NA09

Electric actuator	NA06	NA09	NA15	NA28	NA38	NA60	NA100	NA150	NA200	NA250
Torque	60 Nm	90 Nm	150 Nm	280 Nm	380 Nm	600 Nm	1000 Nm	1500 Nm	2000 Nm	2500 Nm
Operating time	17 s	17 s	20 s	24 s	24 s	29 s	29 s	87 s	87 s	87 s
ISO 5211 pad	F07	F07	F07/F10	F10/F12	F10/F12	F12/F14	F12/F14	F14/F16	F14/F16	F14/F16
Star drive nut	17	17	17	22	27	27	27	36	36	46

DIRECTIVES AND DEVELOPMENT STANDARDS APPLICABLE

Machine 2006/42/EC	Actuator attachments : ISO 5211
Low Voltage Directive 2006/95/EC	Electromagnetic compatibility 2004/108/EC
ATEX 1994/9/EC: ATEX II 2 G EEx d II B T4 – NEMKO 03ATEX1342X (NA-X electric actuator only)	

ELECTRIC ACTUATOR TYPE NA / NA-X

CONSTRUCTION

1	Position indicator	Polycarbonate
2	Condenser	
3	Terminal block	
4	Limit switches	
5	Body / cover	Aluminium alloy
6	Base / enclosure	Aluminium alloy
7	Drive nut	Steel
8	Dome	Polycarbonate
9	Electric motor	
10	Anti-condensation heater	
11	Handwheel	Steel
12	Manual override	Steel
13	Declutching lever	Steel
14	Worm gear	Steel

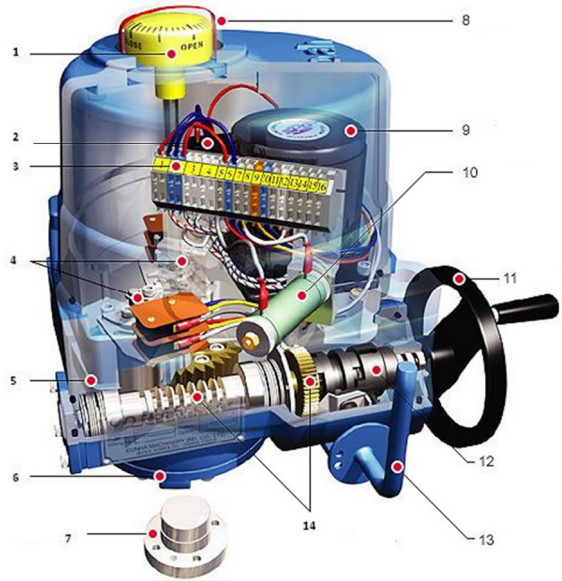

ELECTRICAL CHARACTERISTICS

Motor Protection	Thermal cut-out	Anti-condensation	20 W heater
Limit switches	2 adjustable switches	Electrical connection	2 gland packs M20x1.5
Auxiliary switches	2 dry adjustable switches		

Electric actuator	NA06	NA09	NA15	NA28	NA38	NA60	NA100	NA150	NA200	NA250
Power	15 W	25 W	40 W	40 W	60 W	90 W	180 W	98 W	180 W	180 W
Voltage	380 V – 50 Hz									
Hold current	0.13 A	0.18 A	0.3 A	0.3 A	0.33 A	0.52 A	0.73 A	0.52 A	0.73 A	0.73 A
Inrush current	0.23 A	0.36 A	0.59 A	0.74 A	0.78 A	1.24 A	1.68 A	0.78 A	1.68 A	1.68 A
Voltage	220 V – 50 Hz									
Hold current	0.45 A	0.58 A	0.95 A	0.95 A	1.3 A	1.5 A	2.15 A	1.5 A	2.15 A	2.15 A
Inrush current	0.63 A	0.89 A	1.12 A	1.37 A	1.85 A	2.34 A	3.4 A	2.34 A	3.4 A	3.4 A
Voltage	24 V – 50 Hz									
Hold current	3.2 A	4.3 A	6.5 A	8.1 A						
Inrush current	6 A	8 A	12 A	14 A						
Voltage	24 V DC									
Hold current	2.2 A	3.5 A	4.5 A	6.5 A						
Inrush current	4.1 A	4.1 A	6.6 A	13.8 A						

ELECTRIC ACTUATOR TYPE NA / NA-X

DIMENSIONS (mm)

NA06 to NA100

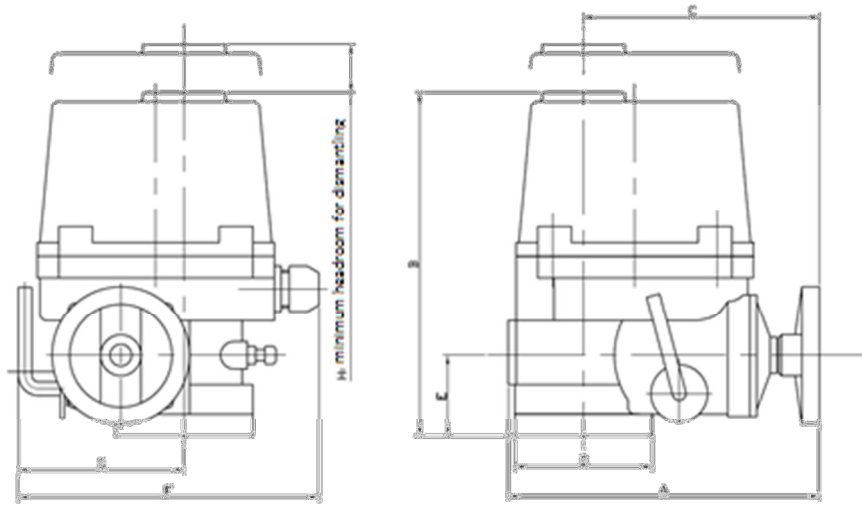

NA150 to NA250

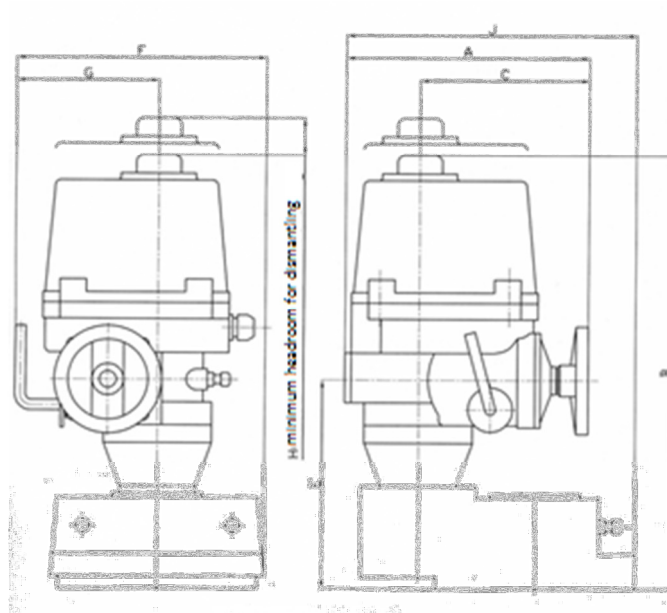

NA	A	B	C	D	E	F	G	H
NA06 - NA09	231	255	175	102	60	223	113	108
NA15	261	255	184	120	60	266	139	108
NA28 - NA38	285	302	202	145	70	300	159	130
NA60 - NA100	325	343	226	175	78	349	191	178
NA150 - NA200 - NA250	325	556	226	-	273	388	191	178

ELECTRIC ACTUATOR TYPE NA / NA-X

OPTIONS

1	NAPIU : feedback potentiometer version
2	NACPT: 4-20 mA position transmitter version
3	NAPCU: 0-10, 2-10 V, 2-20 mA, 4-20 mA regulation card version
4	NALCU: local control version
5	NARBP: integrated battery emergency shutdown device version
6	Earthquake simulation test
7	Low temperature version (-40 °C)
8	IP 68 version
9	Rotation angles 120°, 135°, 180°, 270°