

## KNIFE GATE VALVE CAST IRON METAL-METAL SEAT PN10 S-GATE

Unidirectional cast iron knife gate valve for water, water treatment, chemical pulp, powders, food industry, chemistry  
PTFE packing with stainless steel packing gland nut for a better mechanical resistance.

Centered index allowing the installation of the sensor with a small footprint.

Ribbed support plate for a better rigidity.

Unidirectional metal/metal seat with incomplete tightness : loss factor 1%

**Certificate**

**3.1**



**Size :** DN50 to DN300

**Connection :** Between flanges PN10

**Min Temperature :** -10°C

**Max Temperature :** +90°C

**Max Pressure :** 10 Bars up to DN200

**Specifications :** Rising non rotating stem, non rising handwheel

Unidirectional incomplete tightness

Weak head loss

**Materials :** Cast iron EN GJL-250

**KNIFE GATE VALVE CAST IRON METAL-METAL SEAT PN10 S-GATE**

**SPECIFICATIONS :**

- Opened or closed valve
- Rising non rotating stem, non rising handwheel
- Unidirectional metal/metal tightness with incomplete tightness and loss factor 1% ( Respect the flow direction indicated by the arrow )
- Weak head loss
- Between flanges PN10
- Full crossing threaded lower holes and blind threaded top holes
- With handwheel
- With lever or chain handwheel ( option )
- Possible with bipolar sensor O + C , voltage AC 15-240V 3A, IP66 type XCK M115C
- Deflector ( option )
- 50% epoxy 50% polyester painting blue colour RAL 5005

**USE :**

- Water, water treatment, chemical pulp, powders, food industry, chemistry
- Min and max Temperature Ts : - 10°C to + 90°C

**MAX PRESSURE :**

DN	50	65	80	100	125	150	200	250	300
Ps (Bars)	10	10	10	10	10	10	10	8	6

**NUMBER OF CYCLES TO CLOSE OR OPEN THE VALVE :**

DN	50	65	80	100	125	150	200	250	300
Number of cycles	15	18.75	22.5	27.5	33.75	40	42	52	62

**FLOW COEFFICIENT Kvs ( M3 / h ) :**

DN	50	65	80	100	125	150	200	250	300
Kvs (m3/h)	447	755	1144	1787	2793	4021	7149	11171	16086

**HEAD LOSS CALCULATION :**

$$\Delta p = ( Q / K_v )^2 \times SG$$

Q : flow in m<sup>3</sup>/h

$\Delta p$  : Head loss in bar

SG : Specific gravity (= 1 for water)

Kv : Volume of water in m<sup>3</sup>/h, that will flow through a given restriction or valve opening with a pressure drop of 1 bar at 20°C)

**KNIFE GATE VALVE CAST IRON METAL-METAL SEAT PN10 S-GATE**

**TORQUE VALUES ( in Nm without safety coefficient ) :**

DN	50	65	80	100	125	150	200	250	300
Torque (Nm)	8	10	12	14	16	24	24	38	32

**STEM THREADING SIZE :**

DN	50	65	80	100	125	150	200	250	300
Threading (mm)	Tr 20x4						Tr 25x5		

**RANGE AND ACCESSORIES :**



- Between flanges PN10 cast iron body, AISI 304 gate, metal seat, with handwheel **Ref. 176** from DN50 to DN300



- Bipolar sensors O + C kit **Ref. 9801351 and 9801352** from DN 50 to DN 300



- Sensor (alone) **Ref. 9801350** from DN 50 to DN 300



- Chain handwheel **Ref. 9801790-9801791** from DN 50 to DN 300

**KNIFE GATE VALVE CAST IRON METAL-METAL SEAT PN10 S-GATE**

**RANGE AND ACCESSORIES (SUITE) :**



- Chain ( per meter ) **Ref. 9801795**



- Lever **Ref. 980178** from DN 50 to DN 300



- SS ASTM A351 CF8M Deflector **Ref. 9801800 to 9801808** from DN 50 to DN 300



- SS ASTM A351 CF8M Deflector kit ( with flange gasket ) **Ref. 9801820 to 9801828** from DN 50 to DN 300



- Stainless steel support with bolting **Ref. 9802001 to 9802009** from DN 50 to DN 300

**KNIFE GATE VALVE CAST IRON METAL-METAL SEAT PN10 S-GATE**

**MATERIALS WITH HANDWHEEL ( REF. 176 ) :**

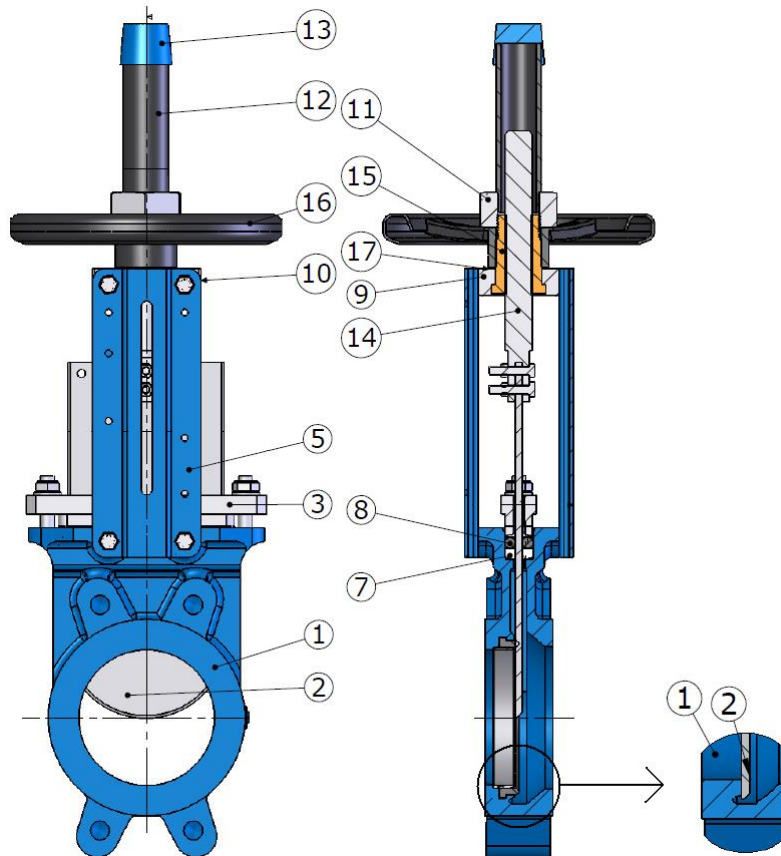

Item	Designation	Materials Ref. 176
1	Body	Cast iron EN GJL-250
2	Gate	AISI 304
3	Packing gland nut	Ductile iron EN GJS-400-15
5	Support	Painted steel
7(+)	Packing ( Tress )	PTFE
8(+)	Packing ( O ring )	NBR
9	Yoke	Steel
10	Oil hole	Steel
11	Fixing screw	Steel
12	Hood	Steel
13	Hood cover	Plastic
14	Spindle	AISI 304
15	Stem nut	Bronze
16	Handwheel	Steel
17	Washer	Brass

(+) : Included in packing gland kit

**KNIFE GATE VALVE CAST IRON METAL-METAL SEAT PN10 S-GATE**

**MATERIALS WITH CHAIN HANDWHEEL ( REF.176 + 980179 ) :**

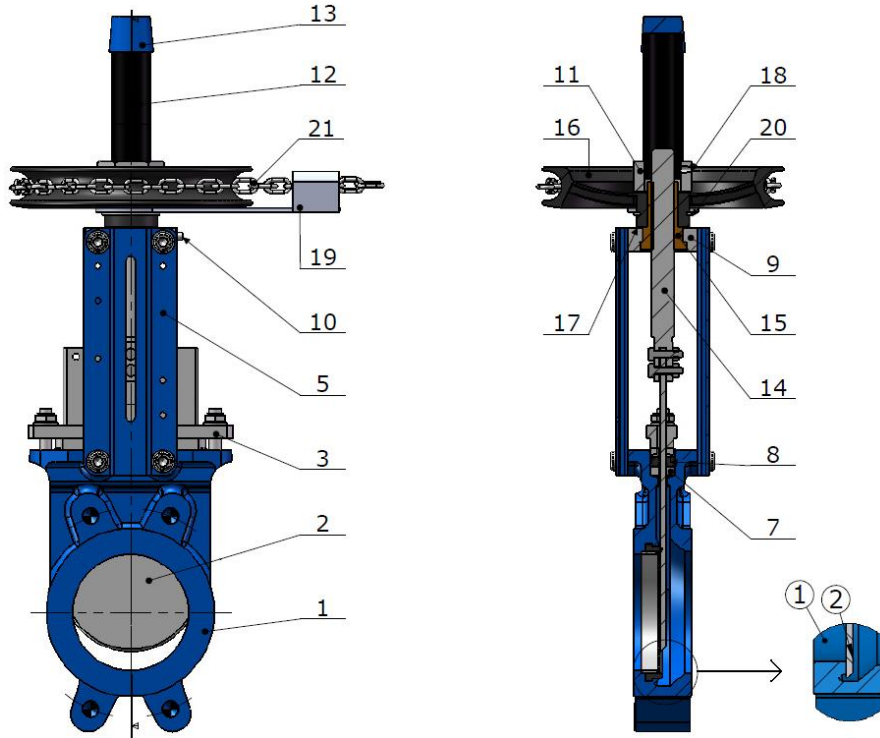

Item	Designation	Materials Ref. 176 + 980179
1	Body	Cast iron EN GJL-250
2	Gate	AISI 304
3	Packing gland nut	Ductile iron EN GJS-400-15
5	Support	Painted steel
7(+)	Packing ( Tress )	PTFE
8(+)	Packing ( O ring )	NBR
9	Yoke	Steel
10	Oil hole	Steel
11	Fixing screw	Steel
12	Hood	Steel
13	Hood cover	Plastic
14	Spindle	AISI 304
15	Stem nut	Bronze
16	Handwheel	Steel
17	Washer	Brass
18	Fixing screw	AISI 304
19	Chain guide	Cast iron
20	Washer	Brass
21	Chain	Steel or stainless steel

(+) : Included in packing gland kit

**KNIFE GATE VALVE CAST IRON METAL-METAL SEAT PN10 S-GATE**

**MATERIALS WITH LEVER ( REF.176 + 980178 ) :**

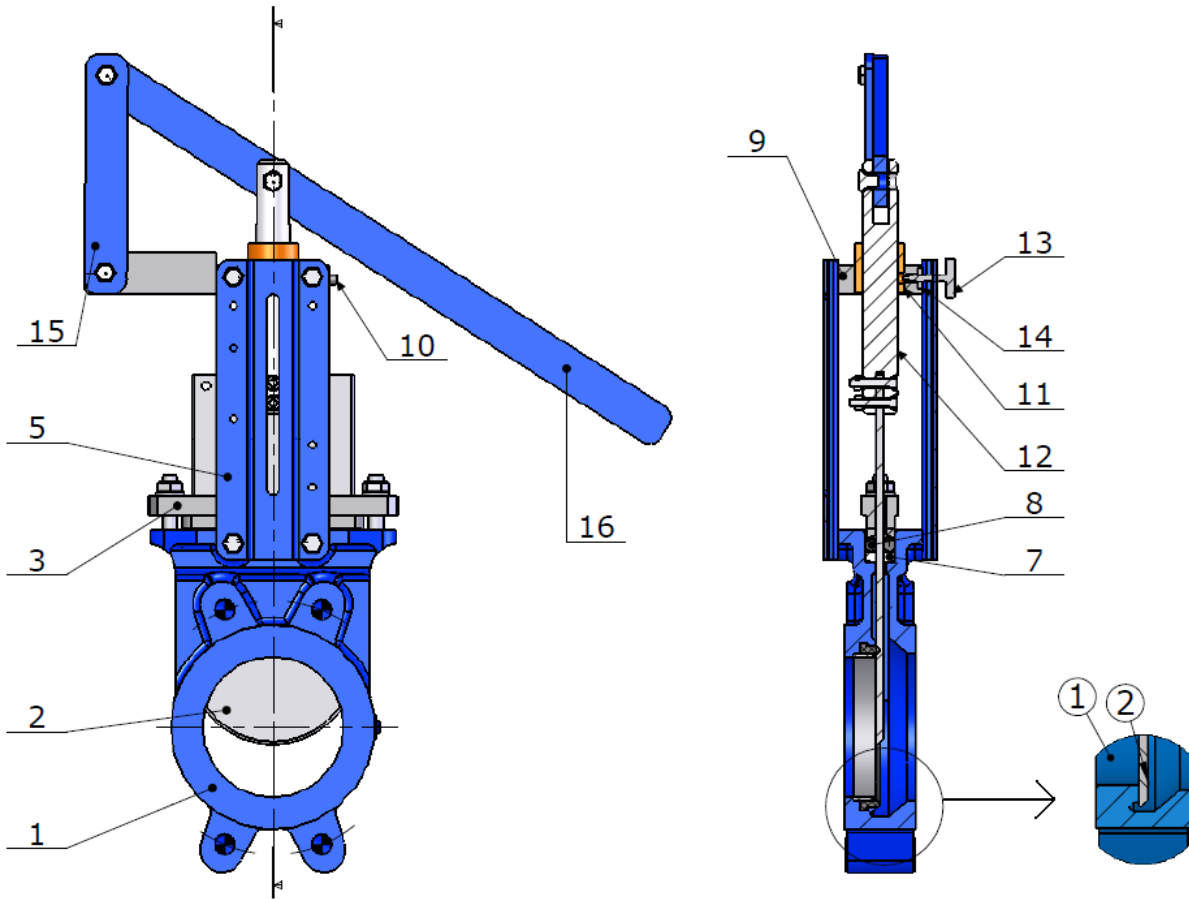

Item	Designation	Materials Ref. 176 + 980178
1	Body	Cast iron EN GJL-250
2	Gate	AISI 304
3	Packing gland nut	Ductile iron EN GJS-400-15
5	Support	Painted steel
7(+)	Packing ( Tress )	PTFE
8(+)	Packing ( O ring )	NBR
9	Yoke	Steel
10	Oil hole	Steel
11	Stem nut	Bronze
12	Spindle	AISI 304
13	Fixing screw	Steel
14	Wedge	Steel
15	Link	Steel
16	Lever	Steel

(+) : Included in packing gland kit

**KNIFE GATE VALVE CAST IRON METAL-METAL SEAT PN10 S-GATE**

**SIZE WITH HANDWHEEL REF.176 ( in mm ) :**

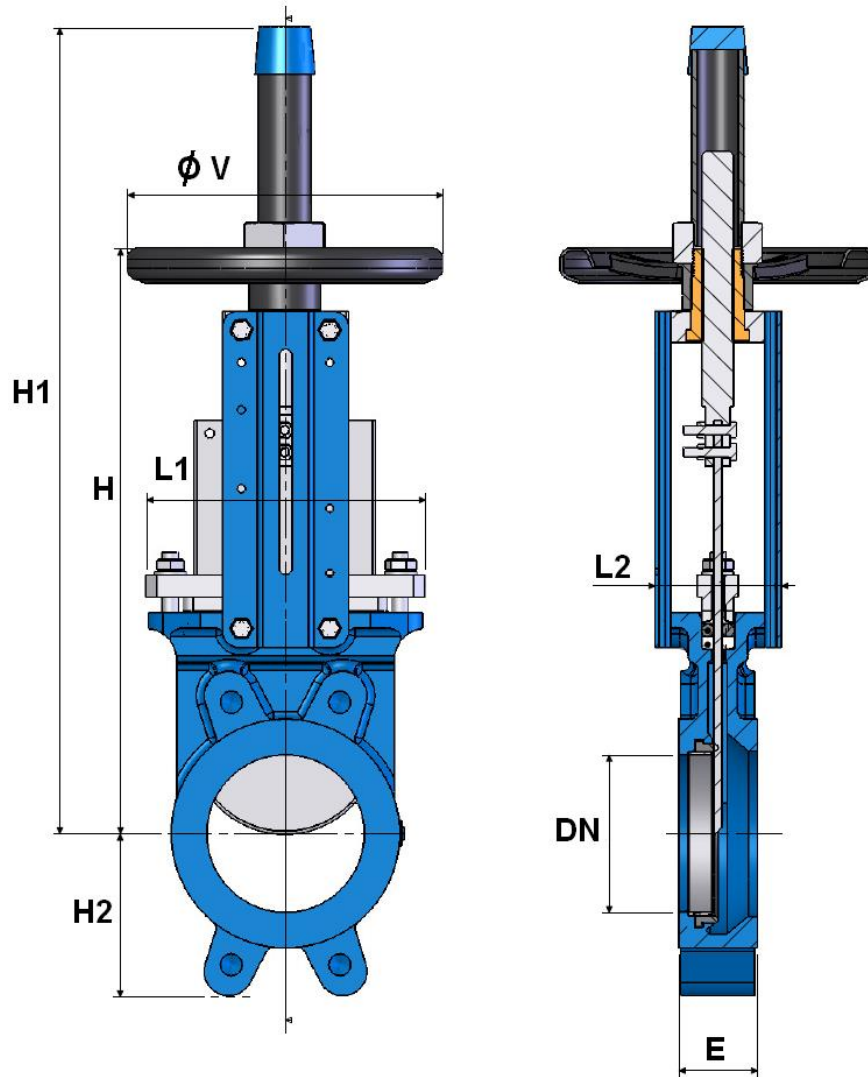

DN	50	65	80	100	125	150	200	250	300
E	40	40	50	50	50	60	60	70	70
H	289	316	342	382	415	458	575	676	776
H1	409	436	462	502	585	637	815	1016	1116
H2	63	70	92	105	120	130	160	198	234
L1	124	139	154	174	192	217	270	326	380
L2	92	92	92	92	102	102	119	119	119
Ø V	185	185	185	185	225	225	325	325	380
Weight ( Kg )	6.53	7.1	8.53	9.8	12.7	16.16	26.8	43.5	50



**KNIFE GATE VALVE CAST IRON METAL-METAL SEAT PN10 S-GATE**

**SIZE WITH CHAIN HANDWHEEL REF.176 + 980179 ( in mm ) :**

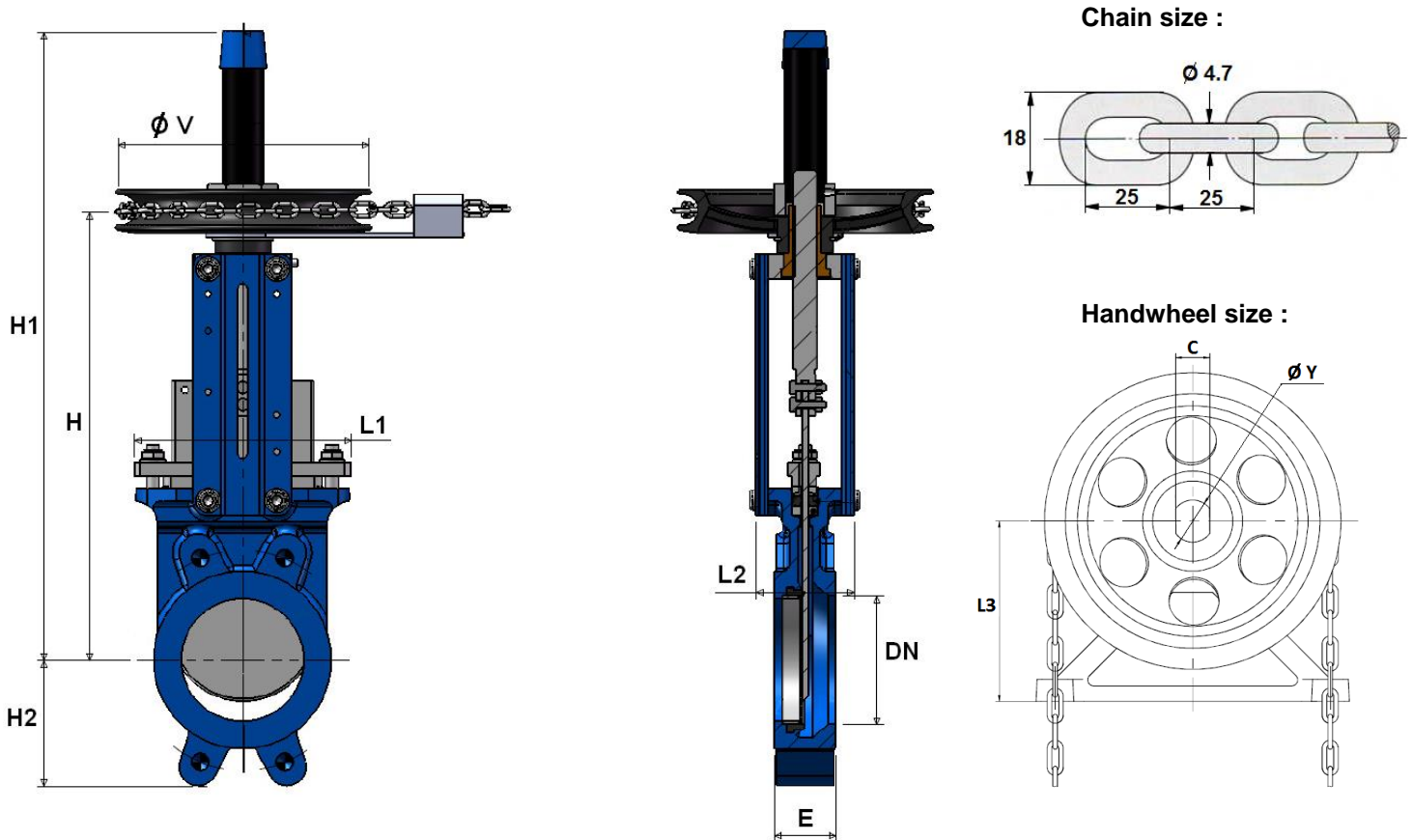

DN	50	65	80	100	125	150	200	250	300
E	40	40	50	50	50	60	60	70	70
H	289	316	342	382	415	458	575	676	776
H1	409	436	462	502	585	637	815	1016	1116
H2	63	70	92	105	120	130	160	198	234
L1	124	139	154	174	192	217	270	326	380
L2	92	92	92	92	102	102	119	119	119
Ø V	212	212	212	212	212	212	296	296	296
Ø Y	34	34	34	34	34	34	42	42	42
C	26	26	26	26	26	26	34	34	34
L3	135	135	135	135	135	135	180	180	180
Weight Ref.176 + 980179 ( Kg )	11.4	12	13.4	14.7	17.6	21	34.3	51	57.5

**KNIFE GATE VALVE CAST IRON METAL-METAL SEAT PN10 S-GATE**

**SIZE WITH LEVER REF.176 + 980178 ( in mm ) :**

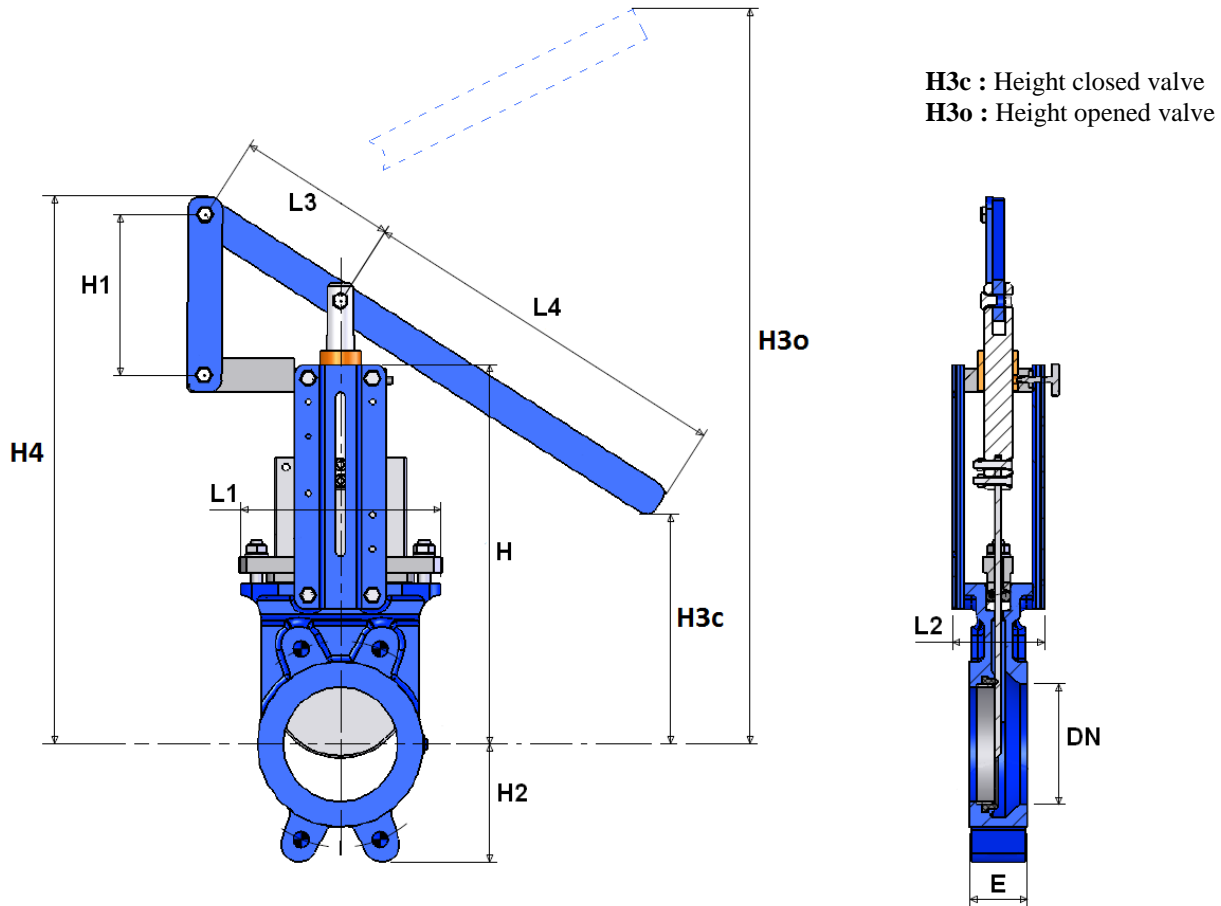

DN	50	65	80	100	125	150	200	250	300
E	40	40	50	50	50	60	60	70	70
H	240	265	290	330	360	412	520	618	718
H1	95	95	95	95	140	140	160	255	255
H2	63	70	92	105	120	130	160	198	234
H3c (closed)	248	263	277	329	301	262	420	315	248
H3o (opened)	452	526	592	704	858	911	1210	1318	1762
H4	343	370	389	436	511	563	690	868	986
L1	124	139	154	174	192	217	270	326	380
L2	92	92	92	92	102	102	120	120	120
L3	140	140	140	140	140	140	230	230	230
L4	330	330	330	330	430	430	630	630	882
Weight Ref.176+980178 (Kg)	8.9	9.8	11	13.3	16	18.9	32.9	53.6	60

**KNIFE GATE VALVE CAST IRON METAL-METAL SEAT PN10 S-GATE**

**SIZE FIXING VALVE THREADED HOLES ( BETWEEN FLANGES PN10 in mm ) :**

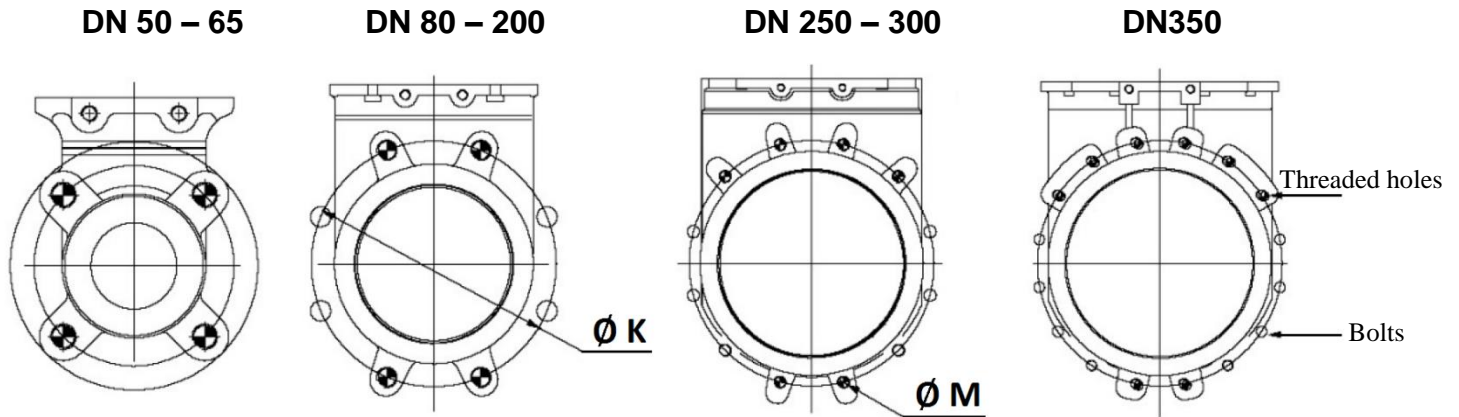

**THREADED LENGHT FOR TOP BLIND HOLES :**

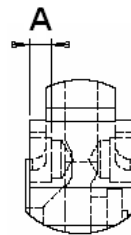

DN	50	65	80	100	125	150	200	250	300
Ø K	125	145	160	180	210	240	295	350	400
Ø M	M16	M16	M16	M16	M16	M20	M20	M20	M20
Nb threaded holes	4	4	4	4	4	4	4	6	6
A	8	8	10	10	10	12	12	15	15
Nb of bolts	0	0	4	4	4	4	4	6	6

**KNIFE GATE VALVE CAST IRON METAL-METAL SEAT PN10 S-GATE**

**DEFLECTOR SIZE ( in mm ) :**

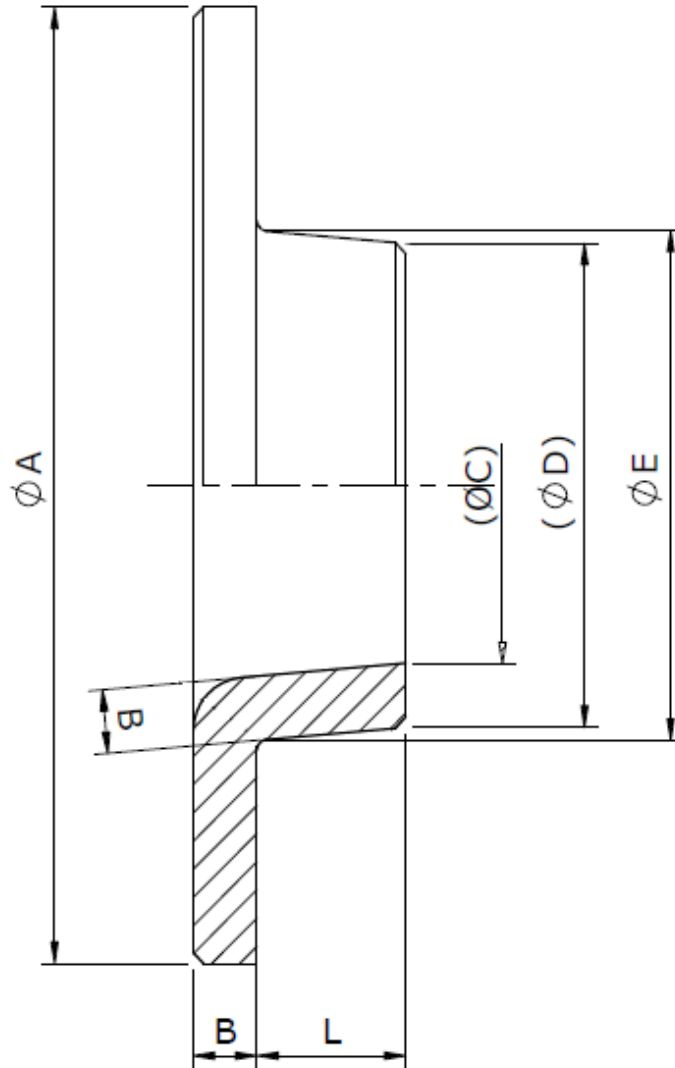

DN	50	65	80	100	125	150	200	250	300
$\varnothing A$	90	105	120	145	170	195	250	310	365
$\varnothing C$	32	47.5	59.5	78.5	104.5	127.5	178.5	226.5	278.5
$\varnothing D$	44	59.5	73.5	92.5	118.5	141.5	192.5	240.5	292.5
$\varnothing E$	48	63	78	98	123	148	198	247	297
B	6	6	7	7	7	7	7	7	7
L	14	14	19	19	18.5	23.5	22.5	27	26

**KNIFE GATE VALVE CAST IRON METAL-METAL SEAT PN10 S-GATE**

**SENSOR SIZE ( in mm ) AND SCHEMA :**

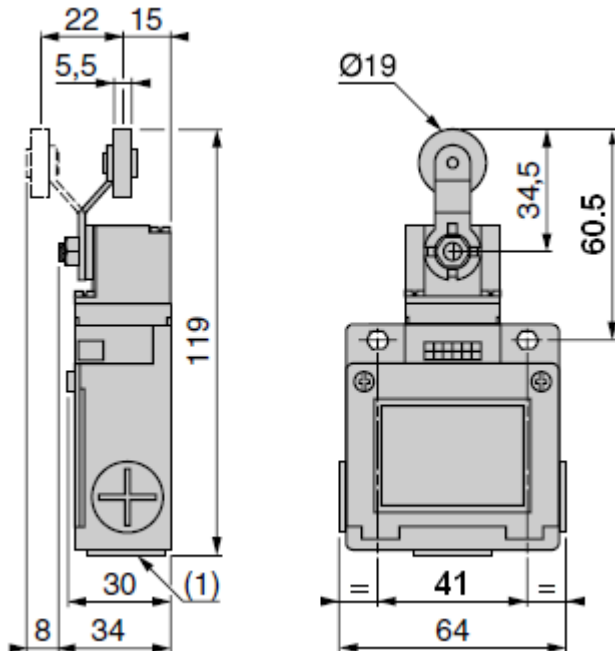

Bipolar sensor O + C  
( XE2S P2151 )

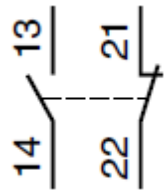

**STANDARDS :**

- Manufacturer certified ISO 9001 : 2015
- DIRECTIVE 2014/68/EU : Products excluded from directive ( Article 4, § 3 )
- Certificate 3.1 on request
- Between flanges PN10 according to EN 1092-1 PN10

**ADVICE :** Our opinion and our advice are not guaranteed and SFERACO shall not be liable for the consequences of damages. The customer must check the right choice of the products with the real service conditions.

**KNIFE GATE VALVE CAST IRON METAL-METAL SEAT PN10 S-GATE**

**INSTALLATION INSTRUCTIONS :**

**GENERAL GUIDELINES :**

- Ensure that the valves to be used are appropriate for the conditions of the installation (type of fluid, pressure and temperature).
- Be sure to have enough valves to be able to isolate the sections of piping as well as the appropriate equipment for maintenance and repair.
- Ensure that the valves to be installed are of correct strength to be able to support the capacity of their usage.
- **Installation of all circuits should ensure that their function can be automatically tested on a regular basis (at least two times a year).**

**INSTALLATION INSTRUCTIONS :**

- **Before installing the valves, clean and remove any objects from the pipes** (in particular bits of sealing and metal) which could obstruct and block the valves.
- **Ensure that both connecting pipes either side of the valve (upstream and downstream) are aligned** (if they're not, the valves may not work correctly).
- **Make sure that the two sections of the pipe (upstream and downstream) match, the valve unit will not absorb any gaps. Any distortions in the pipes may affect the tightness of the connection, the working of the valve and can even cause a rupture.** To be sure, place the kit in position to ensure the assembling will work.
- **If sections of piping do not have their final support in place, they should be temporarily fixed. This is to avoid unnecessary strain on the valve.**
- During installation operation, do not carry the valves by the handwheel.
- Valves can be installed in all positions but we recommend the above positions :

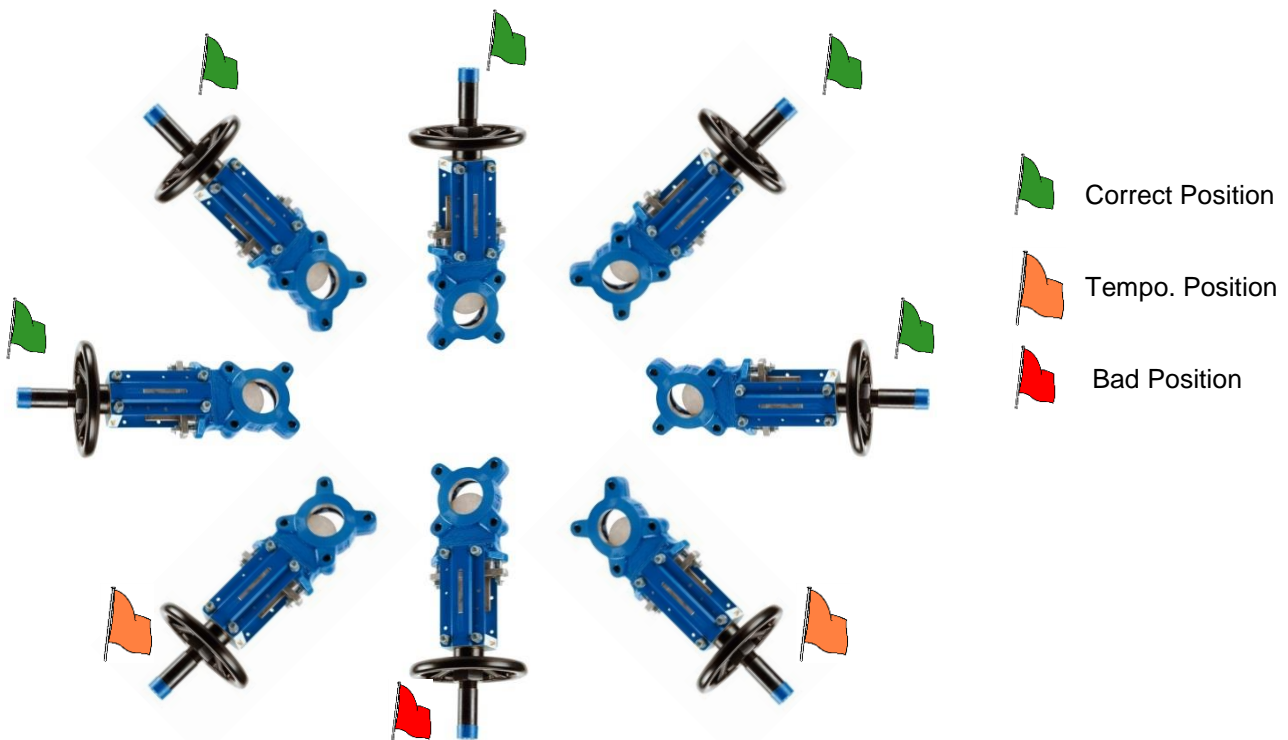

**KNIFE GATE VALVE CAST IRON METAL-METAL SEAT PN10 S-GATE****INSTALLATION INSTRUCTIONS ( SUITE ) :**

- If the valve is installed at the end of the pipe, it must be between 2 flanges.
- The knife gate valves are unidirectional, respect the flow direction indicated on the body by the arrow.  
When using powders, inverse flow direction
- Tighten the bolts in cross. For blind holes, use studs to have a good tightening and tighten them carefully so that they don't touch the gate.
- During cleaning operation, the valves must be opened.
- Tests must be done with cleaned installation and pipe.
- Test must be done with partially opened valve. Test pressure must not exceed valve specification according to ISO 5208.
- Open carefully the valve.
- Tighten the gland packing at the first start of the installation ( with a moderate torque ) so that there's no leakage and the handwheel is easy to operate. Make sure there's no contact between the gate and the gland.
- Keep greased the stem.
- It's recommended to operate the valve ( open and close ) 1 time per month